

Ken Watanabe · Shawn D. Mansfield · Stavros Avramidis

## Application of near-infrared spectroscopy for moisture-based sorting of green hem-fir timber

Received: September 16, 2010 / Accepted: February 7, 2011 / Published online: June 24, 2011

**Abstract** A rapid, non-destructive, in-line method suitable for sorting green hem-fir timbers (115-mm square) based on moisture content was established by near-infrared (NIR) spectroscopy. The accuracy of NIR sorting was compared with a commercial capacitance-type moisture meter. Mixed-species samples consisting of three moisture classes were assessed in this study. The NIR-based prediction model showed positive correlation with the actual calculated values as determined by oven-drying, regardless of knots, surface roughness, and the mix of two wood species. NIR proved to be capable of detecting the moisture content between all pairs of the three moisture groups, whereas the capacitance-type moisture meter failed to establish a significant difference between middle- and high-moisture groups. These findings clearly demonstrate that NIR spectroscopy has a potential to estimate average moisture of green timber indirectly, although it inherently gives only surface moisture content values, as it is limited by scan depth.

**Key words** Near-infrared spectroscopy · Sorting · Hem-fir · Moisture estimation · Green timber

### Introduction

It has long been recognized that timber moisture uniformity can be improved after kiln drying by presorting lumber based on green moisture content estimates. Various techniques used to attain the estimates of green moisture content to facilitate improved overall recovery of dry lumber include weight, density, dielectric properties, and

temperature.<sup>1</sup> In Canada, the adoption of sorting technologies by producers of structural timber has been growing steadily. In addition, drying schedule optimization combined with sorting strategies has been shown to result in better quality and higher yield.<sup>2</sup> However, the current presorting approaches fail to accurately measure the large variability in moisture content that is inherent in green timber.

Near-infrared (NIR) spectroscopy combined with the power of multivariate statistical modeling has been shown capable of predicting wood moisture content. For example, Hoffmeyer and Pedersen<sup>3</sup> developed calibrations for the prediction of moisture in the hygroscopic range in Norway spruce (*Picea abies*) and concluded that NIR spectroscopy is very versatile for such an application. Karttunen et al.<sup>4</sup> determined the moisture distribution of Scots pine (*Pinus sylvestris*) green logs by NIR spectroscopy and showed the existing moisture variation within and between logs. Adedipe and Dawson-Andoh<sup>5</sup> examined the feasibility of using NIR spectroscopy to predict moisture between 0.3% and 80% in yellow-poplar (*Liriodendron tulipifera* L.) veneer sheets. Employing a reduced spectral range (1400–1900 nm), a region ascribed to the two main hydroxyl absorption peaks, gave higher predictive capacity compared to the full spectra. Defo et al.<sup>6</sup> evaluated the effects of grain orientation on predicting moisture content and basic density of red oak (*Quercus* spp.); the spectra collected from the transverse and radial surfaces provided better predictions than those collected from tangential surfaces. Watanabe et al.<sup>7</sup> recently demonstrated that NIR could accurately detect wet-pockets on the surface of kiln-dried western hemlock (*Tsuga heterophylla*). It was also shown that surface moisture content (5–105%) could be predicted in real time at relatively rapid line speed (up to 1 m/s) without averaging NIR scans into a single spectrum, thus making the system very robust and flexible.<sup>8</sup>

Although success has been demonstrated using NIR, its practical application for the wood industry is somewhat restricted because reflected light inherent to the NIR region from the wood surfaces is measured and processed by multivariate analysis, and as such only surface information can be predicted. Therefore, extrapolation of surface

K. Watanabe (✉)  
Forestry and Forest Products Research Institute, 1 Matsunosato,  
Tsukuba, Ibaraki 305-8687, Japan  
Tel. +81-29-829-8306; Fax +81-29-874-3720  
e-mail: kenwatanabe@ffpri.affrc.go.jp

S.D. Mansfield · S. Avramidis  
Department of Wood Science, University of British Columbia,  
Vancouver, BC, V6T1Z4, Canada

information to the entire timber is required as the dimensions of timber increase. To put NIR technology into commercial application for presorting of green timbers or logs, the sorting ability of NIR needs to be assessed in a more practical manner. The purpose of this study was to sort green hem-fir<sup>9</sup> baby-squares using an in-line NIR system based on the predicted moisture content and to evaluate sorting accuracy compared with a commercial capacitance-type moisture meter.

## Materials and methods

### Derivation of prediction models for moisture content

Forty-three kiln-dried timber specimens (105 × 105 mm in cross section and 2.5 m long) of western hemlock (*Tsuga heterophylla*) obtained from two production batches provided by two different mills were cut into small test samples (100 mm long × 105 mm wide × 45 mm thick). NIR spectral information was captured from all three surfaces, offering a range of grain orientations including flat-grain, edge-grain, and in-between grain. In addition, three types of wood (juvenile, sapwood, and heartwood) were evaluated; resulting in a total of nine combinations (three orientations × three wood types) for a total of 90 samples (10 for each combination). The basic density of the samples ranged from 298 to 508 kg/m<sup>3</sup> with a mean value of 368 kg/m<sup>3</sup> and a standard deviation of 45 kg/m<sup>3</sup>.

All samples were oven dried at 103° ± 2°C for 24 h and weighed with a digital balance. Thereafter, the samples were conditioned to target equilibrium moisture contents above 30% in a conditioning chamber (model CL-5488F; Parameter Generation & Control, Black Mountain, NC, USA) for 4 weeks at a temperature and relative humidity of 50°C and 99% RH, respectively. Subsequently, each group was soaked in distilled water for 10 min and then placed in sealed bags for 2 weeks for the water to diffuse and redistribute within the samples. Their weight was again measured before NIR spectra acquisitions. Consequently, moisture content of the samples ranged from 35% to 105% with an average of 64%.

NIR spectra were collected with the LF-1900 spectrometer (Spectral Evolution, North Andover, MA, USA) operating in a diffuse reflectance mode at 4-nm intervals between 1200 and 2116 nm. A fiber optic probe was oriented at 90° above the sample surface, and a piece of commercial micro-porous Teflon was used as reference. The samples were illuminated with a DC lamp oriented at 30° above the sample and aligned parallel to the longitudinal direction of each sample. The distance between the sample surface and the bottom of the spectrometer was 200 mm. The NIR spot area was approximately 77 × 20 mm. A single spectrum was obtained by averaging ten independent scans. Two spectra were collected from each sample, one from the upper surface and the other from the bottom. Thereafter, 108 of the 180 spectra captured were used as the calibration set and the remaining 72 spectra were used as the validation set.

Prior to modeling, spectral data sets were pre-processed using the Savitzky–Golay second derivative spectra with

seven convolution points<sup>10</sup> to remove the effects of baseline and slope. The wavelength range of 1300–2100 nm, which is known to be associated with the hydroxyl groups<sup>5,11</sup> and which corresponded to the highest predictive capability in previous studies,<sup>7</sup> was used. In addition, the upper wavelength limit was reduced to 2050 nm because significant spectral noise was detected between 2050 and 2116 nm in the initial scans.

Multivariate analysis of the preprocessed spectra was performed using Unscrambler version 9.1 software (CAMO, Corvallis, OR, USA). A partial least squares (PLS) regression multivariate technique was used to construct the calibration models consisting of the 108 spectra in the calibration set using a complete cross-validation method. The coefficient of determination ( $R^2$ ) and the root mean square error of cross-validation (RMSECV) were used to assess calibration performance. The RMSECV is a direct estimation of the calibration modeling error.

Determination of the optimum number of principal components (PCs) is very important to prevent overfitting and underfitting of calibration models. The optimal PCs were determined by observing the response of the residual variance with added PCs. When additional PCs did not substantially decrease the residual variance, iterations were terminated. Outliers were selected as being those samples whose residual standard deviation was greater than two times the total standard deviation for all samples. As a result, outliers were detected using this method.

The moisture content of each sample in the validation set was estimated using the calibration model. Predictive quality was evaluated by comparing the calculated values to the measured values. The coefficient of determination ( $R^2$ ), root mean square error of prediction (RMSEP), and ratio of performance to deviation (RPD) served as statistical measures of predictive power. RMSEP values were used to measure how well the calibration model predicts the parameter of interest for a set of unknown samples, which were different from the calibration set. RPD, which is the ratio of the standard deviation of the reference data to the standard error of prediction, provides a further assessment of the calibration model.<sup>12</sup> An RPD of greater than 8 is good for process control, development, and applied research; values of 5 to 8 are adequate for quality control, and 2.5 to 5 are satisfactory for screening.

### Moisture-based sorting of hem-fir timbers

Freshly sawn hem-fir timbers were sourced at a local sawmill. As defined by the Western Wood Products Association, hem-fir is a mixed-species combination of approximately 70% western hemlock (*Tsuga heterophylla*) and 30% amabilis fir (*Abies amabilis*)<sup>9</sup> well known for its large variability of initial moisture content. The acquired samples were 115 × 115 mm in cross section and 4 m in length. The specimens had knots, rough surfaces, and natural variation in color. They were sorted into three moisture/density groups, namely low (0–44%), middle (45–59%), and high (>59%) moisture content, using an in-line commercial

**Fig. 1.** Cutting pattern of small sections (cookies)

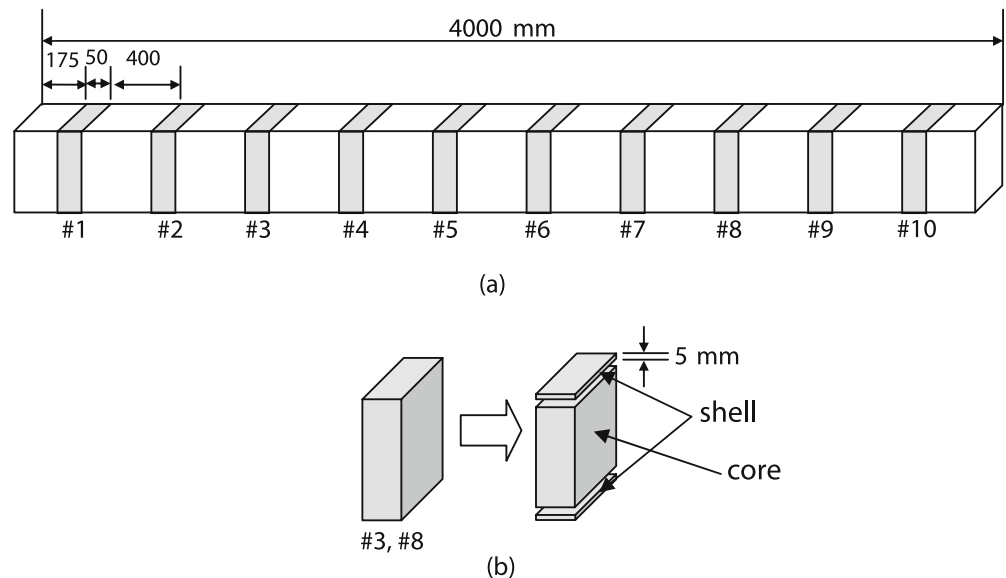

capacitance-type moisture meter (capacitance) designed to sort green timber before drying. Fifty timbers were randomly selected for each group, and therefore 150 ( $50 \times 3$ ) specimens were evenly preclassified into three groups.

The top and bottom surfaces of each specimen were scanned using a pilot-plant in-line NIR system with a line speed of 1 m/s. A detailed description of the NIR system was reported previously.<sup>8</sup> Sixty-six spectra were obtained from each surface. Subsequently, the moisture content of top and bottom surfaces were predicted using the previously developed PLS regression model. The total moisture content of each specimen was extrapolated by averaging the predicted moisture content of both surfaces. All specimens were equally sorted into three groups (high, middle, and low) based on the averaged moisture content.

Ten small sections (cookies) 50 mm thick were then cut from each specimen (Fig. 1a). In addition, the #3 and #8 cookies were cut into shell and core regions to determine their moisture differences (Fig. 1b). As the specimens contained knots and had rough surfaces, the thickness of the shell region was kept at 5 mm, the minimal thickness we could cut without damage. Ten cookies including shell and core regions were weighed individually and then dried in an oven at  $103^\circ \pm 2^\circ\text{C}$  for 2 days. Thereafter, their moisture content was calculated gravimetrically. The average moisture content of each specimen was then determined by averaging the moisture contents of the ten cookies.

## Results and discussion

### Validation of the PLS regression model

The PLS regression model resulted in very high  $R^2$  of 0.93 and 0.93 and low RMSECV/RMSEP of 5.25% and 5.70% for the calibration and the validation, respectively (Table 1). RPD, which serves as a statistical measure of predictive power, was 3.9 in the validation, suggesting that the model

**Table 1.** Summary statistics of partial least squares (PLS) regression model for moisture content

Sample set	Optimal PCs	$n$	$R^2$	RMSECV/ RMSEP (%)	RPD
Calibration	3	108	0.93	5.25	3.80
Validation	3	72	0.93	5.70	3.90

PC, principal component; RMSECV, root mean square error of cross-validation; RMSEP, root mean square error of prediction; RPD, ratio of performance to deviation

is adequate for screening. Predicted moisture contents in the validation set were plotted as a function of the actual values as determined by the oven-dry method (Fig. 2). The solid line indicates where a predicted value equals the measured value ( $R^2 = 1$ ). Deviation from these lines is indicated by RMSEP in Table 1. The PLS regression model showed good agreement and excellent moisture predictability, demonstrating that the resultant PLS regression model can predict moisture content of western hemlock ranging from 35% to 105%, which is the moisture range of the samples used in the model. Industrial moisture meters that have been widely used in sawmills, such as capacitance meters, require a correction for wood density. In contrast, the PLS regression model succeeded in predicting moisture content within the range of basic density ( $298\text{--}508\text{ kg/m}^3$ ) covered by the calibration set, demonstrating that NIR spectroscopy has the advantage of measuring moisture content without the need to correct for wood density.

### Defined wavelength range correlated to moisture content

The raw absorbance spectra for various moisture contents are illustrated in Fig. 3. The two spectral peaks at 1430 and 1910 nm, which are attributed to OH absorption due to water, increased with increasing moisture content (Karttunen et al.<sup>4</sup>). The regression coefficients of the PLS

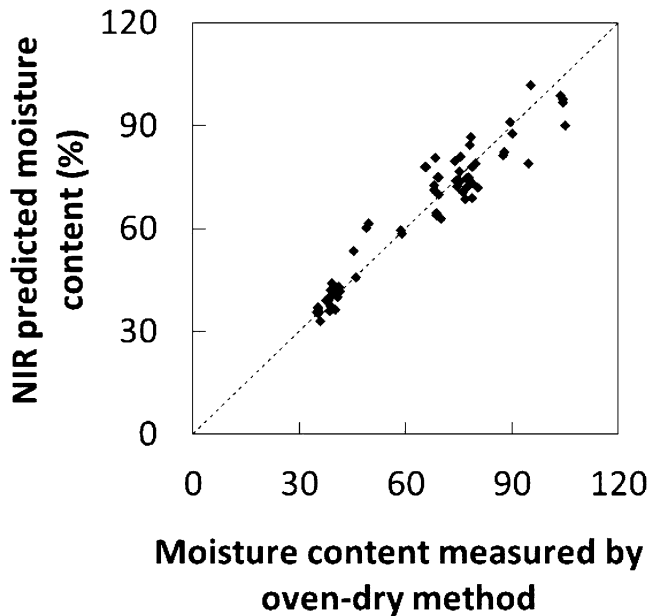

Fig. 2. Near-infrared (NIR) predicted versus measured values in the validation set. Dotted line, target line

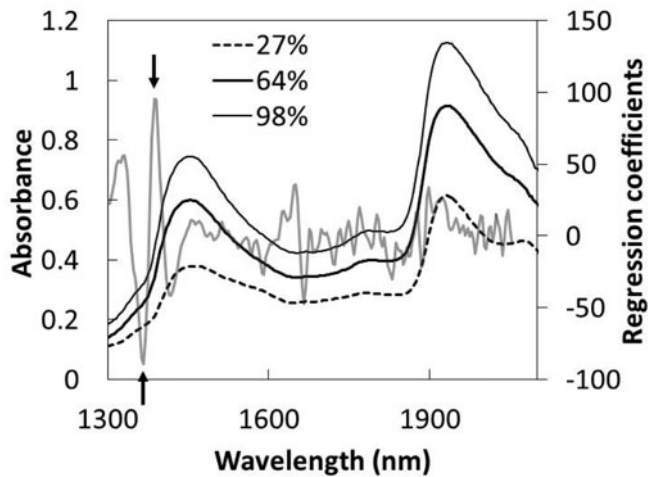

Fig. 3. NIR raw spectra for various moisture contents and regression coefficients of the partial least squares (PLS) regression model. Gray line, regression coefficients; arrows, wavelengths with high positive or negative regression coefficients

regression model were useful in determining important spectral regions correlated to moisture content. These coefficients, at 1430 and 1910 nm, were close to zero, indicating that the two wavelengths had a small impact on the PLS regression model. High negative or positive regression coefficients were observed at 1363 and 1386 nm, which are assigned to the CH deformation and second overtone of CH stretching in cellulose,<sup>13</sup> and the second overtone of OH stretching in water,<sup>14</sup> respectively. This wavelength range could possibly have an important impact on the prediction of moisture content above 30%.

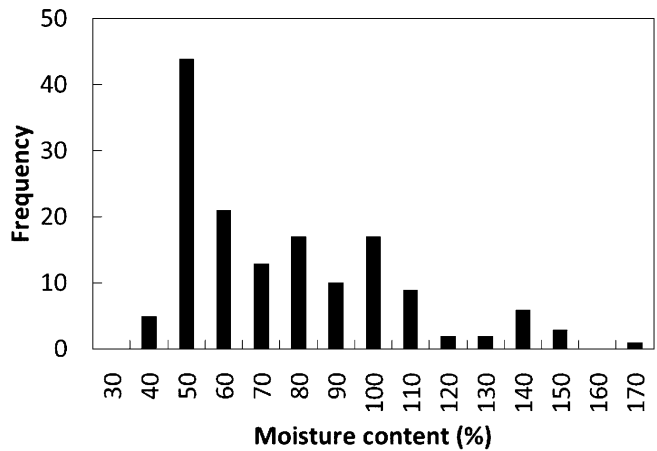

Fig. 4. Distribution of average moisture content of all specimens by oven-dry method

#### Moisture-based sorting of hem-fir timbers

Distributions of average moisture contents for the 150 specimens calculated by the oven-dry method (Fig. 4) ranged from 37% to 167%, with an average of 72%. Similar variation in hem-fir timber has been previously reported.<sup>15,16</sup>

Figure 5 shows the moisture distributions of the pre-classified high, middle, and low moisture content groups sorted by capacitance and NIR, respectively. Overall, the moisture distribution of the low group was the lowest among three groups, whereas that of the high group appeared to be the highest. However, the average moisture content of the middle group sorted by capacitance was slightly higher than that of the high group (Fig. 6), illustrating that capacitance meters inherently lose their accuracy at high moisture content, especially when their predictive ability is impacted by wood density.

One-way analysis of variance (ANOVA) tested the differences in average moisture content among the three groups. The Tukey–Kramer multiple comparison test was used to compare pairwise means. A significant difference in moisture content between all pairs of the three groups was observed when sorted by NIR (one-way ANOVA,  $P < 0.01$ ; Tukey–Kramer multiple comparison test,  $P < 0.01$ ), whereas no significant difference between middle and high groups was apparent when sorted by capacitance. We considered that NIR performed better than the more traditional capacitance-type moisture meter and that an NIR approach is capable of accurately sorting green timber based on moisture content.

The relationship between shell and core moisture content measured from selected cookies was also determined (Fig. 7). In short, it was apparent that there was a good agreement between shell and core moisture content, and as such, demonstrated why NIR can predict average moisture indirectly, although it inherently gives us only surface information. When measured average moisture content versus NIR predicted is plotted (Fig. 8), NIR-predicted moisture content showed a positive correlation with the measured moisture

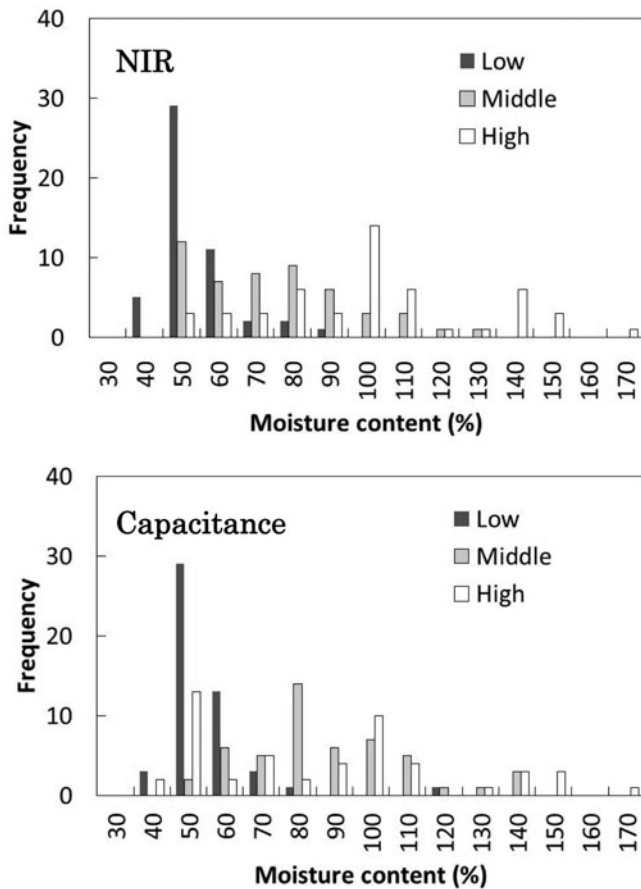

**Fig. 5.** Moisture distributions of high, middle, and low groups sorted by capacitance and NIR, respectively

content, indicating that the in-line NIR system was capable of estimating the average moisture of green timber by scanning the timber surface. It has been demonstrated that NIR spectroscopy has the potential to predict many wood traits, such as basic density,<sup>17,18</sup> shrinkage,<sup>19</sup> grain angle,<sup>20</sup> microfibril angle,<sup>21</sup> and modulus of elasticity,<sup>22,23</sup> which can all impact checking and shape distortions that occur during drying. By means of multiple trait assessment of green timber before drying, more optimized timber sorting could be developed in the future. NIR technology has a conspicuous advantage for timber pre-drying sorting over the other moisture meters.

Measured and NIR-predicted surface moisture content (Fig. 9) showed the  $R^2$  values for moisture content below and above 105% were 0.55 and 0.18, respectively. Surface moisture content above 105% was underestimated; moisture content below 105% showed a positive correlation between predicted and measured values regardless of knots and rough surface, explained by the limitation of the calibration model employed in NIR evaluation. The model was constructed from 100% hemlock samples whose moisture content was below 105%. Therefore, the model is not, in theory, suitable for predicting moisture content of samples over 105%, resulting in the underestimation of moisture content. Watanabe et al.<sup>8</sup> recently reported that moisture content beyond the

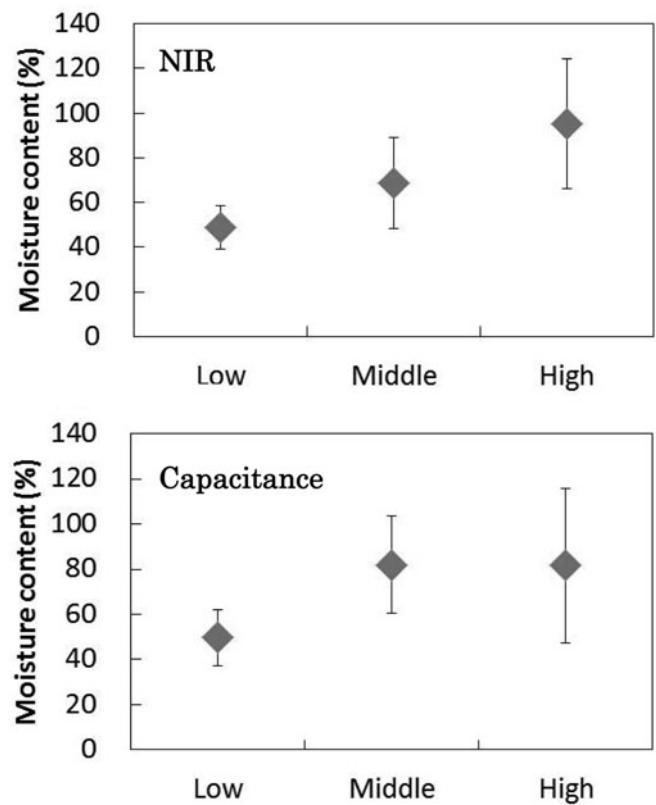

**Fig. 6.** Average moisture content of high, middle, and low groups sorted by capacitance and NIR, respectively. *Plots and error bars* indicate mean value and standard deviations, respectively

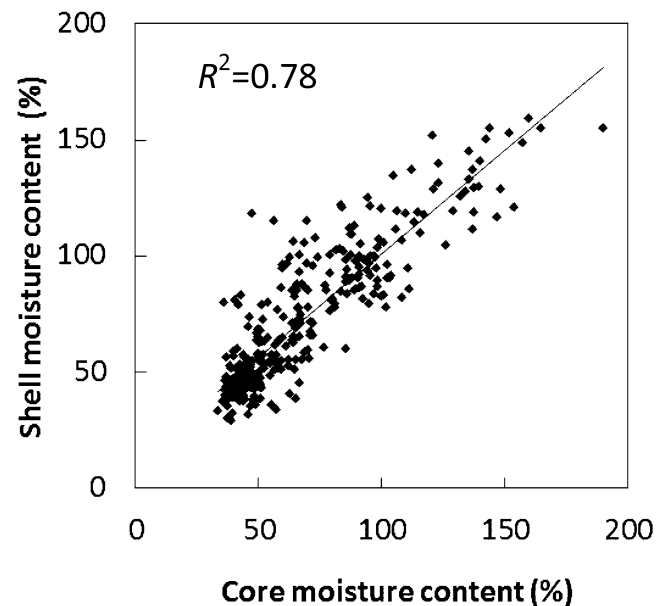

**Fig. 7.** Relationship between shell and core moisture content determined by oven-dry method

predictive range of the calibration model was indeed underestimated. A more suitable model should be developed using samples with higher moisture content (over 105%), which may improve the sorting ability of NIR.

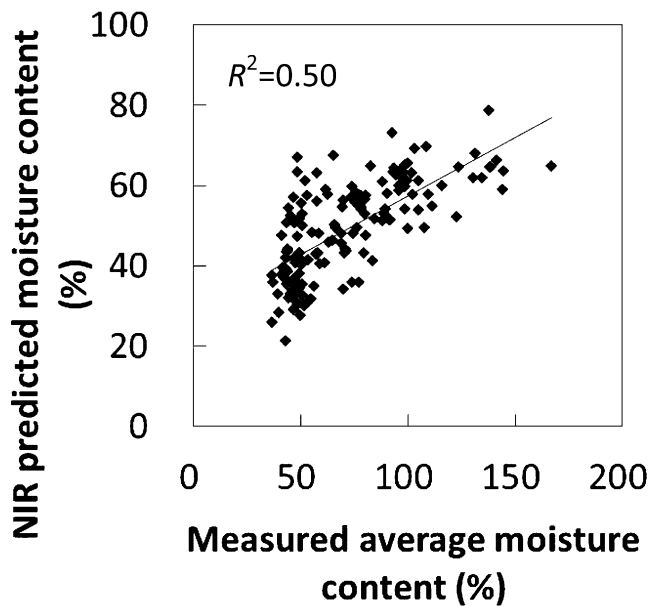

Fig. 8. Plots of measured average moisture content by oven-dry method against NIR predicted

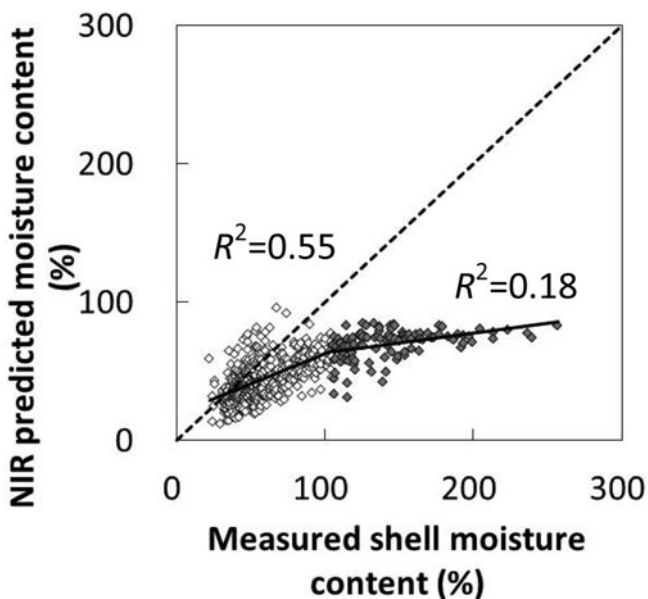

Fig. 9. Measured and NIR-predicted surface moisture content. Dotted line, target line. The plots are separated into two moisture ranges, below and above 105%

The PLS regression model tended to underestimate moisture content ranging from 35% to 105% as measured content increased (Figs. 8, 9). The relationship between measured and predicted moisture content was non-linear and may be a result of surface drying. Surface drying during NIR measurement was shown to occur (Karttunen et al.<sup>4</sup>) when the moisture distribution of cross sections of logs were scanned. The authors suggest that the deviation between measured and NIR-predicted moisture content resulted from the drying effect on the surface, and therefore the effect of surface drying needs to

be considered. In our study, each NIR scan required less than 3 s, and therefore surface drying is likely negligible. It should be kept in mind, however, that this study was conducted on specimens that, although they were “green,” were at least a few weeks old. It is well known that timber surfaces will immediately start drying following sawmilling, and therefore the difference between surface and core measures will increase with time. Such surface drying caused significant moisture gradient within a shell region, resulting in the nonlinear relationship in Figs. 8 and 9. In general, the moisture gradient perpendicular to the surface increases as the measured moisture content of a shell region increases. Furthermore, the difference between measured and NIR-predicted moisture content increases with increasing moisture gradient, because predicted moisture content is reflected on the surface layer of less than 3 mm,<sup>7</sup> whereas measured moisture content shows the average of a shell region with 5-mm thickness. This difference is most likely the reason the PLS regression model tended to underestimate moisture content as the measured shell moisture content increased.

Because the rate of surface drying depends on environmental conditions, which vary with season and location, improving the PLS regression model to compensate for the underestimation of moisture content is difficult. Meanwhile, surface drying can be prevented if the NIR measurements are taken immediately after conversion to timber. This method may be the simplest way to solve the surface-drying issue that caused the underestimation of moisture content, so that the predictive results may be improved.

## Conclusion

Partial least squares (PLS) regression models capable of predicting the surface moisture content of *Tsuga heterophylla* timber were developed based on NIR spectra of small samples conditioned to set moisture contents above 30%. Following the establishment of the model, the moisture content of commercially produced green hem-fir timbers (115 mm square) was predicted using the in-line NIR system combined with the developed PLS regression model with a line speed of 1 m/s. In addition, the timbers were sorted into three groups based on the predicted moisture content, and the sorting ability of NIR was compared with the commercial capacitance-type moisture meter.

There was a good correlation between shell and core moisture content by the oven-dry method, demonstrating that moisture content can indeed be predicted by NIR, which showed a positive correlation with the measured oven-dried values. There was a significant difference in moisture content between all pairs of the three groups sorted by NIR, whereas no significant difference between the middle and high moisture groups were shown when sorted by the capacitance-type moisture meter. These results demonstrate that an NIR approach is capable of sorting green timber based on moisture content.

**Acknowledgments** This project was funded through a grant provided by the BC Coast Forest Products Association and the BC Forest Inno-

vation Investment. The hem-fir timbers used in this work were provided by Western Forest Products—Alberni Pacific Division sawmill.

## References

- Oliveira LC (2003) Drying sorted spruce-pine-fir (spf) timber. In: Proceedings of the 8th International IUFRO Wood Drying Conference, Brasov, Romania, pp 178–184
- Elustondo DM, Oliveira LC (2009) A method for optimizing timber sorting before kiln-drying. *For Prod J* 59:45–50
- Hoffmeyer P, Pedersen JG (1995) Evaluation of density and strength of Norway spruce wood by near infrared reflectance spectroscopy. *Holz Roh-Werkst* 53:165–170
- Karttunen K, Leinonen A, Sarén M-P (2008) A survey of moisture distribution in two sets of Scots pine logs by NIR-spectroscopy. *Holzforschung* 62:435–440
- Adedipe EO, Dawson-Andoh B (2008) Predicting moisture content of yellow-poplar (*Liriodendron tulipifera* L.) veneer using near infrared spectroscopy. *For Prod J* 56:28–33
- Defo M, Taylor AM, Bond B (2007) Determination of moisture content and density of fresh-sawn red oak timber by near infrared spectroscopy. *For Prod J* 57:68–72
- Watanabe K, Hart F, Mansfield SD, Avramidis S (2010) Detection of wet-pockets on the surface of *Tsuga heterophylla* (Raf.) Sarg. by near infrared (NIR) spectroscopy. *Holzforschung* 64:55–60
- Watanabe K, Hart F, Mansfield SD, Avramidis S (2010) Near infrared technology applications for quality control in wood processing. In: Proceedings of the COST E53 Conference, Edinburgh, UK, pp 332–341
- Western Wood Products Association (WWPA) (1997) Hem-fir species facts. <http://www2.wwpa.org/WESTERNSPECIES/HemFir/tabid/299/Default.aspx>. Accessed Sep 8, 2010
- Savitzky A, Golay MJE (1964) Smoothing and differentiation of data by simplified least square procedures. *Anal Chem* 36:1627–1639
- Kelley SS, Rials TG, Groom LR, So CL (2004) Use of near infrared spectroscopy to predict the mechanical properties of six softwoods. *Holzforschung* 58:252–260
- Williams PC, Sobering DC (1993) Comparison of commercial near infrared transmittance and reflectance instruments for analysis of whole grains and seeds. *J Near Infrared Spectrosc* 1:25–32
- Siesler HW, Ozaki Y, Kawata S, Heise HM (2002) Near-infrared spectroscopy principles, instruments, applications. Wiley, Weinrich, pp 180–183
- Ali M, Emsley AM, Herman H, Heywood RJ (2001) Spectroscopic studies of the ageing of cellulosic paper. *Polymer* 42:2893–2900
- Jessome AP (1977) Strength and related properties of woods grown in Canada. Forestry Technical Report 21. Eastern Forest Products Laboratory, Ottawa, Ontario, Canada
- Zhang Y, Oliveira L, Avramidis S (1996) Drying characteristics of hem-fir squares as affected by species and basic density presorting. *For Prod J* 46:44–50
- Thygesen LG (1994) Determination of dry matter content and basic density of Norway spruce by near infrared reflectance and transmittance spectroscopy. *J Near Infrared Spectrosc* 2:127–135
- Schimleck LR, Michell AJ, Raymond CA, Muneri A (1999) Estimation of basic density of *Eucalyptus globulus* using near-infrared spectroscopy. *Can J For Res* 29:194–201
- Taylor AM, Baek SH, Jeong MK, Nix G (2008) Wood shrinkage prediction using NIR spectroscopy. *Wood Fiber Sci* 40:301–307
- Gindl W, Teischinger A (2002) The potential of vis- and NIR-spectroscopy for the nondestructive evaluation of grain-angle in wood. *Wood Fiber Sci* 34:651–656
- Kelley SS, Rials TG, Snell LH, Groom LH, Sluiter AD (2004) Use of near infrared spectroscopy to measure the chemical and mechanical properties of solid wood. *Wood Sci Technol* 38:257–276
- Kelley SS, Rials TG, Groom LR, So C-L (2004) Use of near infrared spectroscopy to predict the mechanical properties of six softwoods. *Holzforschung* 58:252–260
- Fujimoto T, Kurata Y, Matsumoto K, Tsuchikawa S (2008) Application of near infrared spectroscopy for estimating wood mechanical properties of small clear and full length lumber specimens. *J Near Infrared Spectrosc* 16:529–537